

Windstop Locking Lever

Vehicle Type: **Boxster/Boxster S**

Model Year: **As of '97 (V)**

Concerns: **Attachment of windstop middle section on roll-over bar.**

- **Windstop noises when driving (rattling, clicking)**
- **New locking levers**
- **Parts for replacement requirements**

Filing: **Remove Boxster technical information bulletin Group 6, 11/97, dated 10-30-98 from your Boxster Technical Manual and file this one. Affix the attached decal across Technical Bulletin Book 0, page 105.**

Information: Since March 12, 2004 production, the locking levers (right and left) for the securing of the windstop middle section have been changed. The locking levers are now available separately using normal parts ordering procedures.

In case of complaints, the two locking levers (right and left) are to be replaced and not the windstop middle section.

Lever Identification

Figure 1, Item A, shows the new version (right locking lever). The spring element of the new lever (arrow) is slimmer and more flexible compared to the previous version (Item B).

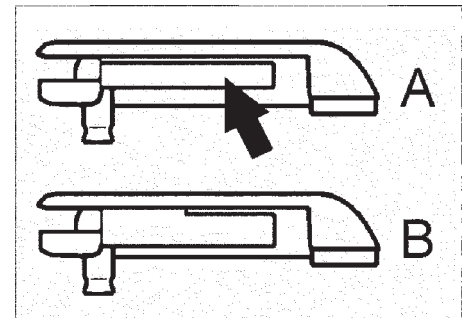

Figure 1

Introduction: March 12, 2004, as of the following VINs:

- 98 64S 62 0778 USA
- 98 64S 66 0647 USA
- 98 84U 62 1175 USA
- 98 84U 66 1298 USA

Parts Information:

Part Number	Description
986 561 737 01 01C	New / left locking lever
986 561 737 00 01C	Previous / Ditto, no longer available
986 561 738 01 01C	New / right locking lever
986 561 738 00 01C	Previous / Ditto, no longer available

Work Procedure:

In order to install a new locking lever, the windstop middle section must be removed.

1. **Removing locking lever** (Figure 2). Using a small slotted screwdriver, disengage the locking lever by pressing down the axle and pull the lever out of the windstop frame.
2. **Installing locking lever.** Audibly engage the new locking lever in the windstop frame.

Note:

To prevent a reduction of pre-tension force in the engagement connection, the locking lever should not be repeatedly disengaged from and engaged in the windstop frame.

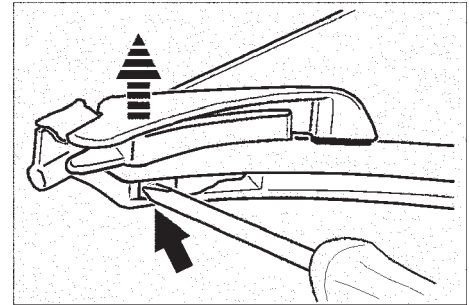

Figure 2

Literature:

- Boxster Technical Manual*, Group 6:
 > Repairs: 68 47 19 – Removing/installing windstop
Boxster M.Y. 04 Owner's Manual:
 > Chapter "Mobile roofs" – Windstop

Important Notice: Porsche Cars N.A Technical Bulletins are intended for use by professional technicians, not a "Do-it-yourselfer." They are written to inform these technicians of conditions that may occur on some vehicles, or to provide information that could assist in the proper service of a vehicle. Special tools may be required to perform certain operations identified in these bulletins. Use of tools and procedures other than those recommended in these bulletins may be detrimental to the safe operation of your vehicle. Properly trained technicians have the equipment, tools, safety instructions and know-how to do a job properly and safely. If a condition is described, do not assume that the bulletin applies to your vehicle, or that your vehicle will have that condition. See your Porsche Dealer for information on whether your vehicle may benefit from the information. Part numbers listed in these bulletins are for reference only. Always check with your authorized Porsche dealer to verify correct part numbers.

©2004 Porsche Cars North America, Inc.

Dealership	Service Manager	_____	Shop Foreman	_____	Service Technician	_____	_____	_____	_____
Distribution	Asst. Manager	_____	Warranty Admin.	_____	Service Technician	_____	_____	_____	_____
Routing									

Dr. Ing. h.c. F. Porsche AG is the owner of numerous trademarks, both registered and unregistered, including without limitation the Porsche Crest®, Porsche®, Boxster®, Carrera®, Cayenne®, Tiptronic®, VarioCam®, PCM®, 911®, 4S®, and the model numbers and distinctive shapes of Porsche's automobiles such as, the federally registered 911 automobile. The third party trademarks contained herein are the properties of their respective owners. Porsche Cars North America, Inc., believes the specifications to be correct at the time of printing. However, specifications, standard equipment and options are subject to change without notice. Printed in the USA